

CODE	Dn1	Dn2	D	L1	L2	L3	L	H
12ERDE2520	25	20	36	40	37	62	85	57
12ERDE3220	32	20	43	43	37	69	85	64,5
12ERDE3225	32	25	44	39,5	39,5	70	84,5	64,5
12ERDE4020	40	20	52,5	48	40	79,5	95	74



EloFIT

ITEM: **ERDE**

DESC: RIDUZIONE ELETTRISALDABILE
ELECTROFUSION REDUCER
PE100 SDR11 PFA/PN16



DRAWING No:
EL10147

SHEET OF REV.
1 3 -3

www.nupiindustriaitaliane.com - info@nupinet.com

All dimensions have to be considered in millimeters with 5% tolerance if not otherwise mentioned excluding values as per standard EN 1555 (gas) and/or EN 12201 (water)

CODE	Dn1	Dn2	D	L1	L2	L3	L	H
12ERDE4032	40	32	55	47	42	-	95	74
12ERDE5032	50	32	64	49,5	41,5	-	100	85
12ERDE5040	50	40	64	49,5	47,5	-	103	85
12ERDE6332	63	32	81,5	55,5	42	-	118	99
12ERDE6340	63	40	81,5	55	45	-	118	99
12ERDE6350	63	50	81,5	55,5	50	-	118	99
12ERDE7563	75	63	97	60	57	-	125	114
12ERDE9050	90	50	117	72	49	-	142	133,5
12ERDE9063	90	63	115	68	62	-	150	131
12ERDE9075	90	75	116	73,5	65	-	152,5	131
12ERDE1163	110	63	135	72,5	63	-	160	150,5
12ERDE1190	110	90	135	73	68,5	-	158	150,5
12ERDE1263	125	63	150	76	65	-	162,5	167
12ERDE1290	125	90	150	80	70	-	160	167
12ERDE1211	125	110	156	70	71,5	-	161	167
12ERDE1690	160	90	192	81	72	-	177	207
12ERDE1611	160	110	192	81	77	-	182	207
12ERDE1612	160	125	186	76	73,5	-	179	201

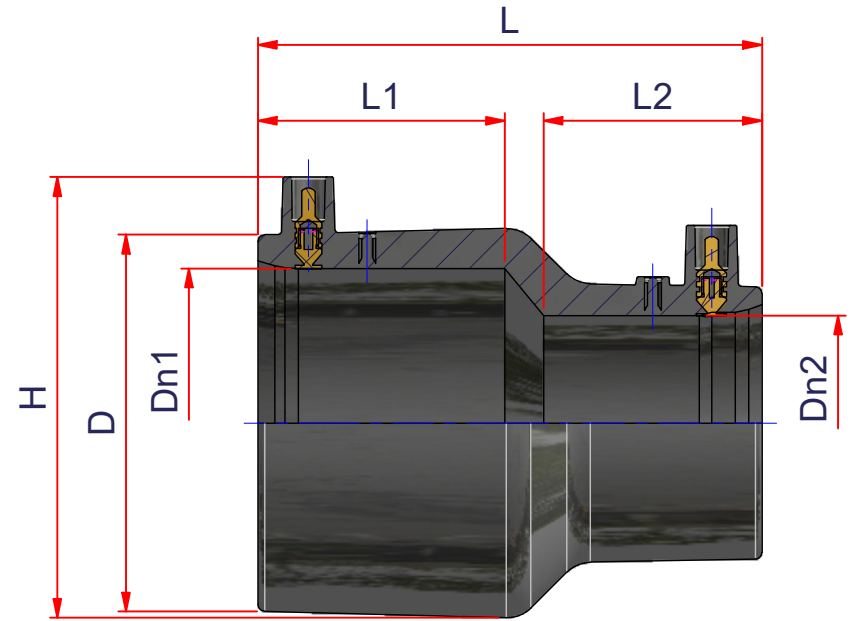

EloFIT

ITEM: **ERDE**

DESC: RIDUZIONE ELETTROSALDABILE
ELECTROFUSION REDUCER
PE100 SDR11 PFA/PN16



DRAWING No:
EL10147

SHEET OF REV.
2 3 -3

www.nupiindustriaitaliane.com - info@nupinet.com

All dimensions have to be considered in millimeters with 5% tolerance if not otherwise mentioned excluding values as per standard EN 1555 (gas) and/or EN 12201 (water)

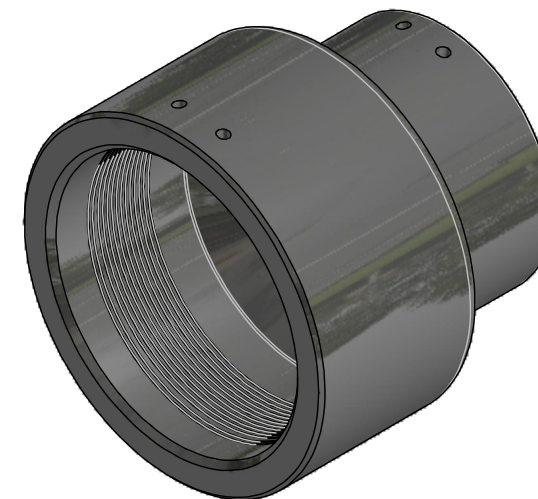
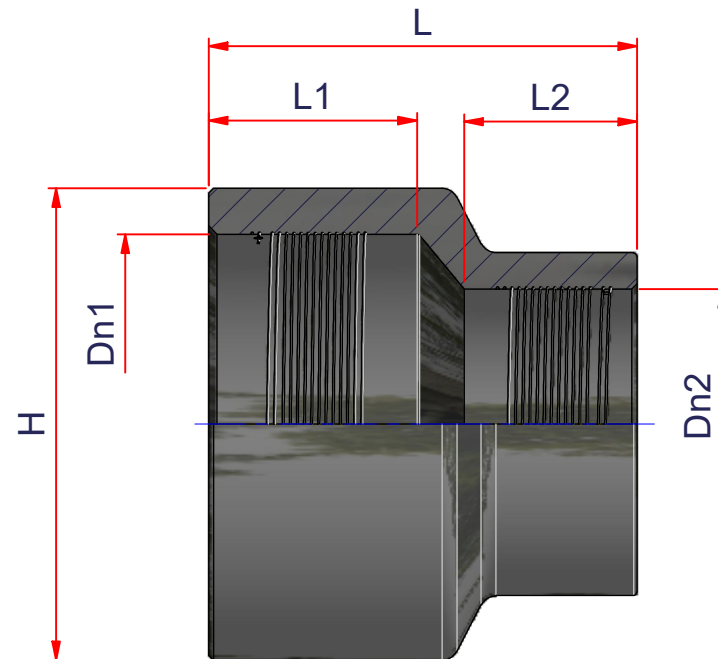

CODE	Dn1	Dn2	L1	L2	L	H
12ERDE2016	200	160	113	102	225	250
12ERDE2018	200	180	113	112	235	250
12ERDE2216	225	160	124	103	255	278
12ERDE2218	225	180	124	112	255	278
12ERDE2220	225	200	124	113	255	278
12ERDE2518	250	180	124	113	255	278
12ERDE250200	250	200	119	98	242	305
12ERDE2522	250	225	135	125	275	308
12ERDE3125	315	250	120	120	270	390
12ERDE3128	315	280	155	130	295	390



EloFIT

ITEM: **ERDE**

C:\Vault_Temp\Disegn\ISchede Tecniche\Elofit metric\Electrofusion fittings\EL10147.dwg

DESC: RIDUZIONE ELETTROSALDABILE
ELECTROFUSION REDUCER
PE100 SDR11 PFA/PN16



DRAWING No:
EL10147

SHEET OF	REV.
3 3	-3